

## Operating manual

Calibrator for vibration transducers

### HD2060



Companies / Brands of GHM

Members of GHM GROUP:

**GREISINGER**  
**HONSBERG**  
*Martens*  
**IMTRON**  
**Delta OHM**  
**VAL.CO**

[www.deltaohm.com](http://www.deltaohm.com)

Keep for future reference.

# INDEX

<b>1</b>	<b>INTRODUCTION .....</b>	<b>3</b>
<b>2</b>	<b>TECHNICAL CHARACTERISTICS .....</b>	<b>4</b>
<b>3</b>	<b>DESCRIPTION AND MOUNTING OF TRANSDUCER .....</b>	<b>5</b>
<b>4</b>	<b>TRANSDUCER CALIBRATION .....</b>	<b>8</b>
<b>5</b>	<b>CALIBRATOR CONFIGURATION .....</b>	<b>10</b>
<b>6</b>	<b>BATTERY .....</b>	<b>12</b>
<b>7</b>	<b>STORAGE OF INSTRUMENTS .....</b>	<b>13</b>
<b>8</b>	<b>SAFETY INSTRUCTIONS .....</b>	<b>13</b>
<b>9</b>	<b>ORDERING CODES .....</b>	<b>14</b>

# 1 INTRODUCTION

The calibrator HD2060 generates mechanical vibration amplitude controlled with precision and frequency stabilized by a quartz. Coupling a transducer to the vibrating base of the calibrator it is possible to check its sensitivity to acceleration, velocity or displacement. The presence of a rechargeable internal battery, the weight and the small dimensions as well as the low sensitivity to environmental parameters make it easy to use the calibrator in the field. The calibrator is equipped with a feedback system capable of accurately maintaining the amplitude level set, regardless of the load associated with the mass of the transducer (within the limits stated in the technical specifications).

The mechanical vibrations generated by the calibrator are very stable over the time, with a typical drift of 1% per year. In order to maintain the accuracy, we recommend the annual calibration at DELTA OHM metrological laboratories. The calibrator notifies the user about the need to make the periodic check by displaying alternately the signs "cal" and "exp" on the display.

The backlit display provides a clear indication of acceleration, frequency and the reaching of the set level. In case of exceeding the maximum permissible load or in case of low battery, the calibrator alerts the user by displaying an error message and the operation of the vibrating base is turned off. The automatic stop of the vibration after the set time and the automatic shutdown function prevent the discharge of the battery.

The calibrator is equipped with screws and accessories for mounting the transducers, with external power supply for charging the battery and with calibration report.

## **Applications:**

- In-the-field calibration of acceleration, velocity and displacement transducers.
- Calibration of acceleration sensors used for the measurement of vibrations transmitted to men in the workplace, according to the standard ISO 8041:2005.
- Calibration of acceleration sensors used to evaluate buildings vibration.

## **Main specifications:**

- Two frequencies of emission: 15.915 Hz at 1 m/s<sup>2</sup> and 0,1 g  
159.155 Hz at 10 m/s<sup>2</sup> and 1 g
- Low distortion accelerations, independent from the mass of the transducer
- Absence of dispersed magnetic field.
- Backlit display with the indication of the acceleration level stabilization.
- Internal rechargeable battery which allows 2 hours of continuous operation at 15.915 Hz and 7 hours of continuous operation at 159.155 Hz.

## 2 TECHNICAL CHARACTERISTICS

<b>Maximum load of the vibrating base</b>	Traction force: 10 N Pressure: 30 N Transverse: 2 N	<b>The exceeding of the limits may permanently damage the vibrating base</b>
<b>Mass of the transducer</b>	Maximum 250 g at 15.915 Hz Maximum 30 g at 159.155 Hz	
<b>Emission frequency tolerance</b>	± 0.1%	
<b>Emission amplitude tolerance</b>	± 3%	
<b>Distortion</b>	Less than 3% at 15.915 Hz Less than 0.5% at 159.155 Hz	
<b>Duration of individual emission</b>	Settable from 120 seconds to 10 minutes. Automatic turn OFF	
<b>Transverse acceleration</b>	Less than 10% at 15.915 Hz Less than 20% at 159.155 Hz	
<b>Mounting of the transducer</b>	Threaded hole UNF 10-32 at 90° ±1°	
<b>Working temperature/RH</b>	0...+40 °C / 0...85 %RH not condensing	
<b>Stabilization time</b>	Less than 30 s	
<b>Display</b>	Backlit with indication of: <ul style="list-style-type: none"> <li>▪ Frequency generated</li> <li>▪ Acceleration generated</li> <li>▪ Stabilization of the vibration</li> <li>▪ Remaining battery charge</li> <li>▪ Calibration deadline</li> </ul>	
<b>Power supply</b>	<b>Rechargeable</b> NiMH battery pack 1.2V x 4, capacity 1600 mA/h ( <b>BAT-40</b> ) 100-240 Vac / 12 Vdc 1 A stabilized power supply ( <b>SWD10</b> )	
<b>Autonomy with full charged battery</b>	2 hours of continuous use at 15.915 Hz 7 hours of continuous use at 159.155 Hz	
<b>Battery charging time</b>	4 hours at 12 Vdc 1A	
<b>Auto power off</b>	After an inactive period of time equal to 3 times the time of solicitation set	
<b>Dimensions</b>	115 x 93 x 63 mm	
<b>Weight</b>	930 g including battery	

### 3 DESCRIPTION AND MOUNTING OF TRANSDUCER

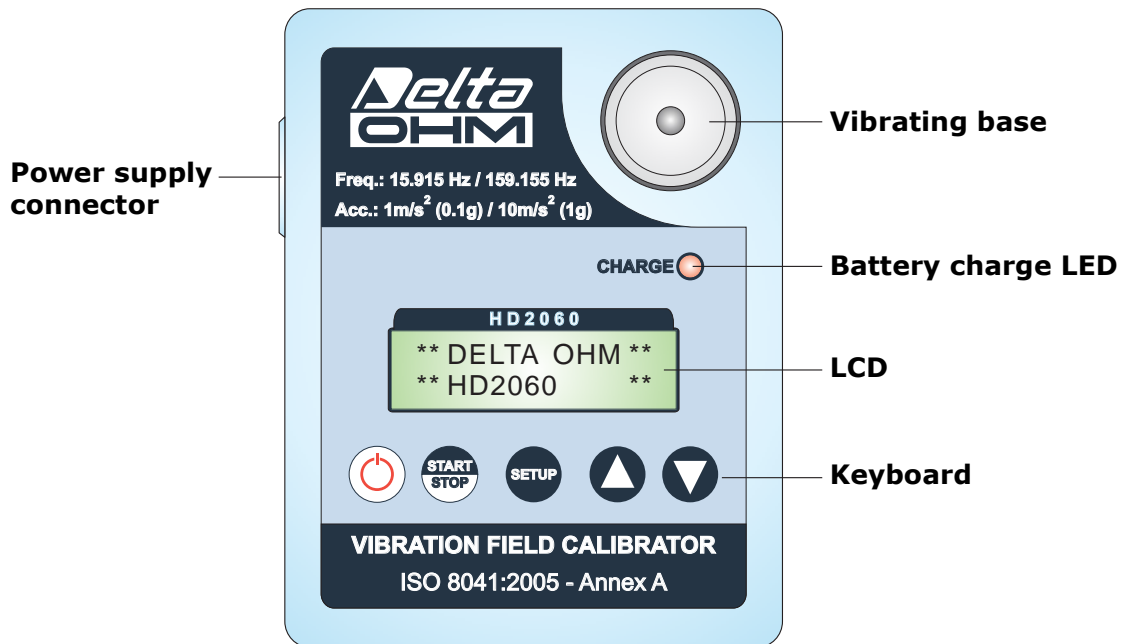

Fig. 3.1: Description

#### TRANSDUCER MOUNTING

The calibrator HD2060 presents a flat circular steel fixing base (see Figure 3.1), resistant to abrasions, with a UNF 10-32 threaded hole in the center for the mounting of the transducers.

The fixing base can freely rotate on its housing so as to avoid damage to the calibrator when mounting the sensors and applying the tightening. To fix the accelerometer using a screw it's sufficient a 1-2 Nm tightening force, compatible with a manual operation. For maximum measurements repeatability, the use of a torque wrench is recommended.

Maximum applicable forces to the fixing base are: 30 N pressure force, 10 N traction force and 2 N transverse force (see picture 3.2). **Applying a load which exceeds specified limits can permanently damage the HD2060 calibrator.**

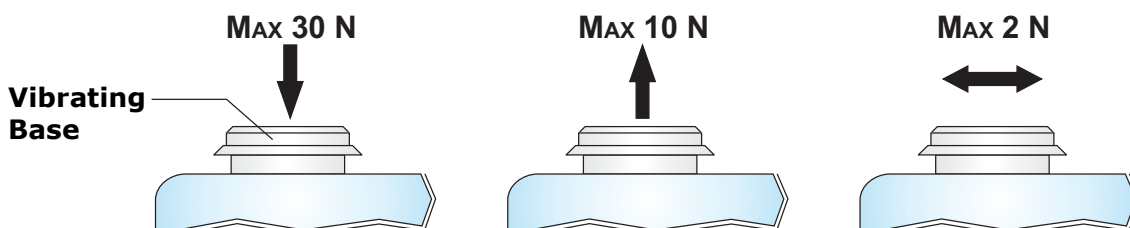
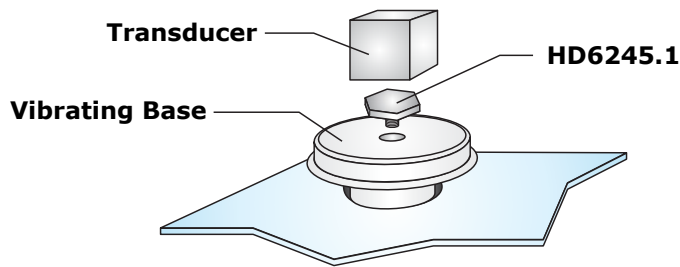

Fig. 3.2: Maximum load limits for vibrating base

As an alternative to screw mounting, it's possible to fix the sensor onto vibrating base using double-sided tape, wax or quick glue; for this can be used the supplied adapter HD6245.1 (see picture 3.3) to be mounted between vibrating base and transducer. To

avoid an excessive pressure on the vibrating base, we recommend to glue the transducer on the HD6245.1 adapter before screwing it to the vibrating base.



**Fig. 3.3: Adhesive Mounting**

To calibrate axes orthogonal to the mounting axis on triaxial accelerometers, it is supplied the adapter HD2060.20, complete with UNF 10-32 dual threading screw to fix the adapter to the mounting base and screw with UNF 10-32 threading to fix the sensor to the adapter (see picture 3.4).

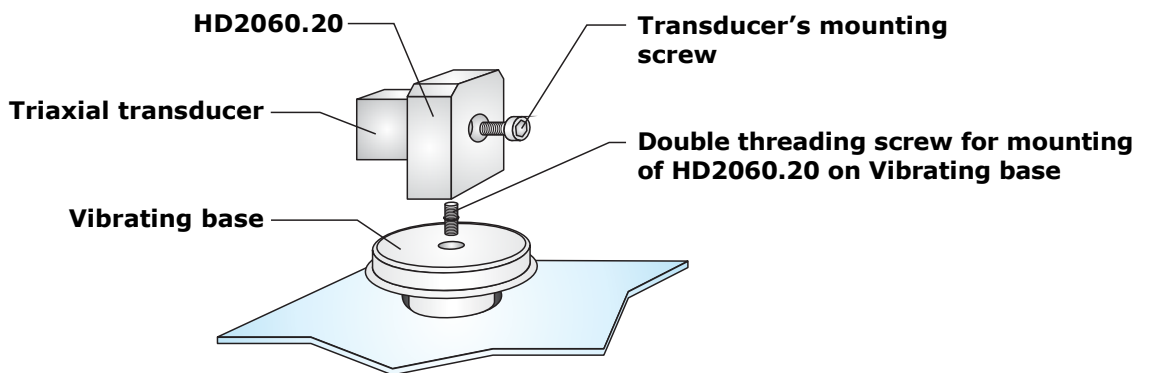

**Fig. 3.4: Use of adapter HD2060.20**

If you use the HD2060.20 adapter to calibrate at 16 Hz perpendicular axis of a triaxial accelerometer having a mass greater than 30 g, it is necessary to balance the load using a counterweight equal to that of the transducer to be mounted, as shown in figure 3.5.

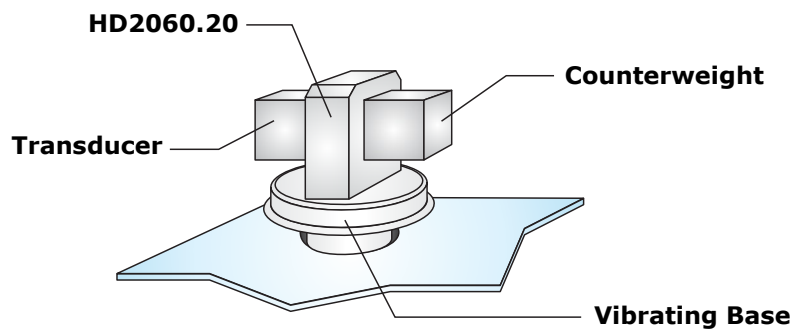

**Fig. 3.5: Use of counterweights**

Calibrator must be placed on a flat horizontal surface, possibly free from external vibrations. In order to check that transmitted vibration level from supporting surface is

negligible it is sufficient, after transducer has been fixed to the mounting base, to verify that acceleration on the measurement chain with calibrator turned OFF is below 1/5 of calibration level. For example, if a calibration has to be made at 15.915 Hz with 1 m/s<sup>2</sup> amplitude level, acceleration on the measurement chain when calibrator is OFF should be less than 0.2 m/s<sup>2</sup>.

During calibration solicitation it's necessary to avoid unbalances on the base, taking care of transducer's connection cable positioning, in order to minimize the transverse load. Transducer should be mounted so that the load is centered on the base.

## 4 TRANSDUCER CALIBRATION

HD2060 can calibrate acceleration, velocity and displacement sensors. Emission frequencies are chosen to allow an easy conversion among the three measurement units as shown in the table below.

Frequency [Hz]	Acceleration [m/s <sup>2</sup> ]	Velocity [mm/s]	Displacement [μm]
15.915	1	10	100
	0.98	9.81	98.1
159.155	10	10	10
	9.81	9.81	9.81

Selection of the right frequency depends on the type of transducer and measurement application. For example, according to ISO 8041:2005 requirements, vibration transducers used in the workplace to evaluate vibration transmitted to hand –arm system , must be checked at 159.155 Hz, while those used for vibrations transmitted to the whole body must be checked at 15.915 Hz.

Some transducers are designed for measurement at very low frequencies, and cannot be calibrated at 160 Hz. If the application or the type of transducer don't put constraints to the choice, 159.155 Hz frequency is preferable because, in addition to higher acceleration level, provides a lower distortion and lower sensitivity to vibrations induced from the support surface.

### Procedure:

1. After the transducer has been correctly mounted on the vibrating base, power ON the calibrator by pressing the ON/OFF key.



2. Use the arrow keys to select the emission frequency.

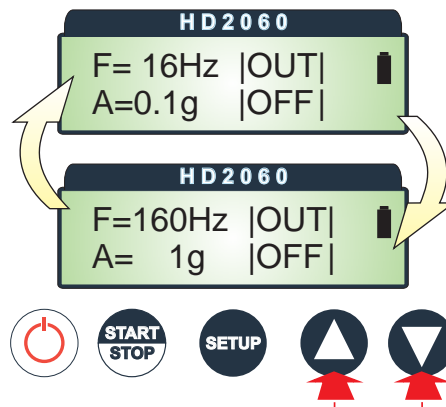

Note: as concerns modification of acceleration amplitude and emission duration please see configuration paragraph.



3. In order to start emission, press START/STOP key.

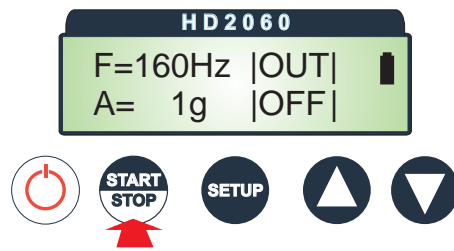

4. On the display is shown the indication WT ("Wait") until vibration emission is sufficiently steady. When emission is stable, it appears the indication ON.

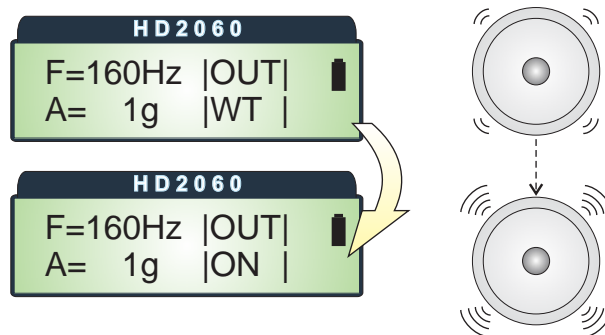

5. Emission stops automatically after the time period set on the calibrator is elapsed. In order to manually stop emission, press the START/STOP key.

## 5 CALIBRATOR CONFIGURATION

By sequentially pressing the SETUP key, the following information are displayed:

- Generated Acceleration (AMPL. SETUP)
- Emission Duration (VIBR. TIME)
- Date and time (DATE TIME)
- Calibrator serial number (SERIAL NUM.)
- Calibration Date (CALIB. DATE)
- Firmware Version (FIRM. VER.)

### Setting Acceleration Amplitude:

Press SETUP key until the AMPL. SETUP screen is shown, then select required acceleration value using the arrow keys.

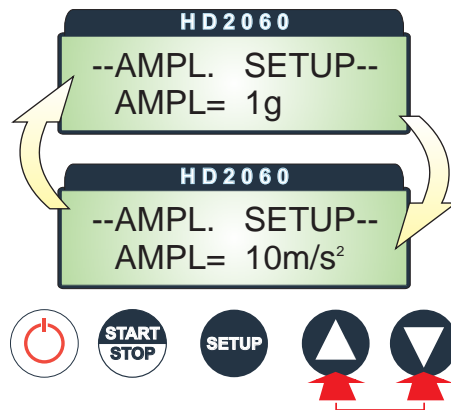

Acceleration values that can be set, depend on the emission frequency selected. For emission frequency of 15.915 Hz can be set acceleration amplitudes of 1 m/s<sup>2</sup> and 0.1g (0.98 m/s<sup>2</sup>). For emission frequency of 159.155 Hz can be set acceleration amplitudes of 10 m/s<sup>2</sup> and 1g (9.81 m/s<sup>2</sup>).

### Setting Emission Duration:

Press the SETUP key until the VIBR. TIME screen appears, then select required emission duration using the arrow keys.



Duration can be set from 120 seconds up to 10 minutes in steps of 10 seconds.

### Setting date and time:

Press SETUP key until the DATE TIME screen appears, then modify the year field using the arrow keys.



In order to set the next fields (month, day, hour, minute), just press SETUP key until the desired field starts blinking, then modify it using the arrow keys.

### **Exit from configuration mode:**

In order to exit from the configuration mode, hold down the SETUP key for at least 2 seconds.

Settings are stored in the calibrator's internal memory and remain stored even if the device is turned OFF. When the calibrator is powered ON, it always starts with the latest configuration set.

## 6 BATTERY

The battery symbol on the display continuously provides the charge battery status. As the battery discharges, the symbol "empties". When the charge is insufficient for correct device operation, the symbol starts blinking and it will be not possible to activate the emission of the vibrating base.

In order to charge the batteries, connect the SWD10 power supply to the input plug positioned on the calibrator's side. During battery charge, the "CHARGE" red LED is ON. The LED will turn OFF when the charge is completed. The time necessary for a full charge is about 4 hours.

Power supply has a dual function: supplies the device and charges the NiMH battery. When power supply is plugged in, the battery symbol on the display, is substituted by the symbol of a plug.

**In order to preserve over time the battery capacity, it is recommended to make a complete charge cycle at least one time every six months.**

The battery can be charged and discharged hundreds times, but it loses its capacity with the use during time. If, when the battery is fully charged, the operation autonomy is not sufficient, it's necessary to replace the battery pack.

As spare part use only original Delta OHM battery pack **BAT-40** and proceed as follows:

- If plugged in, disconnect external power supply.
- Loosen the two screws to remove the cover of battery housing placed on the bottom of calibrator.
- Disconnect the battery taking care not to tear the wires.
- Connect the new battery: the connector has a reference that avoids uncorrect operation.
- Place the new battery in the housing.
- Close the battery housing tightening the two screws.

Note: dispose used batteries according to safety normatives. Don't throw used batteries in the municipal waste; do not put the batteries into contact with flames or high temperature surfaces.

## 7 STORAGE OF INSTRUMENTS

Storage conditions of the instrument:

- Temperature: 0...+40 °C.
- Humidity: less than 90 %RH no condensation.
- For storage, avoid places where:
  - There is a high level of humidity;
  - Instruments are exposed to direct sun radiation;
  - Instruments are exposed to a high temperature source;
  - There are strong vibrations;
  - There is vapor, salt and/or corrosive gases.

## 8 SAFETY INSTRUCTIONS

### General instructions for safety

The instrument has been manufactured and tested in compliance with the safety standard EN61010-1:2010 "Safety requirements for electrical equipment for measurement, control and laboratory use" and left the factory in a safe and secure technical condition.

The regular functioning and operational safety of the instrument can be ensured only if all normal safety measures, as well as the specific measures described in this manual, are followed.

The regular functioning and operational safety of the instrument can only be guaranteed under the climatic conditions specified in the manual.

Do not use the instruments in places where there are:

- Rapid ambient temperature variations that may cause condensation.
- Corrosive or flammable gases.
- Direct vibrations or bumps to the instrument.
- High-intensity electromagnetic fields, static electricity.

If the instrument is transported from a cold environment to a warm one, or vice versa, the formation of condensation may cause disturbances to its functioning. In this case, wait until the temperature of the instrument reaches room temperature before putting into operation.

### Obligations of the User

The user of the instrument must ensure compliance with the following standards and guidelines for the treatment of hazardous materials:

- EEC directives on workplace safety
- National low regulations on workplace safety
- Accident prevention regulations

## 9 ORDERING CODES

**HD2060** Portable calibrator for acceleration, velocity and displacement transducers. Double emission frequency (15.915 Hz and 159.155 Hz). Backlit LCD display. Power supply with internal rechargeable battery or external 12Vdc power supply. Includes: support (**HD2060.20**) with UNF 10-32 screw for triaxial accelerometers mounting, insulated base (**HD6245.1**) with integrated UNF 10-32 screw for accelerometers adhesive mounting, rechargeable internal battery (**BAT-40**), mains power supply (**SWD10**), carrying case and calibration report.

### Accessories

**SWD10** 100-240 Vac / 12 Vdc 1 A stabilized power supply.

**BAT-40** Rechargeable NiMH battery pack 1.2 V x 4.

**HD6245.1** Insulated base with integrated UNF 10-32 screw for accelerometers adhesive mounting

**HD2060.20** Support for the lateral mounting of tri-axial accelerometers with 10-32 UNF mounting screw

**Delta OHM LAT N° 124 metrology laboratories are ISO/IEC 17025 accredited by ACCREDIA in Temperature, Humidity, Pressure, Photometry/Radiometry, Acoustics and Air Speed. They can provide certificates for the accredited quantities.**



**DICHIARAZIONE DI CONFORMITÀ UE  
EU DECLARATION OF CONFORMITY**

**Delta Ohm S.r.L. a socio unico – Via Marconi 5 – 35030 Caselle di Selvazzano – Padova – ITALY**

Documento Nr. / Mese.Anno: **5097 / 07.2019**  
Document-No. / Month. Year :

Si dichiara con la presente, in qualità di produttore e sotto la propria responsabilità esclusiva, che i seguenti prodotti sono conformi ai requisiti di protezione definiti nelle direttive del Consiglio Europeo:  
*We declare as manufacturer herewith under our sole responsibility that the following products are in compliance with the protection requirements defined in the European Council directives:*

Codice prodotto:  
*Product identifier :* **HD2060**

Descrizione prodotto:  
*Product description :* **Calibratore portatile per trasduttori di vibrazione  
Portable calibrator for vibration transducers**

I prodotti sono conformi alle seguenti Direttive Europee:  
*The products conform to following European Directives:*

Direttive / Directives	
2014/30/EU	Direttiva EMC / EMC Directive
2014/35/EU	Direttiva bassa tensione / Low Voltage Directive
2011/65/EU - 2015/863/EU	RoHS / RoHS

Norme armonizzate applicate o riferimento a specifiche tecniche:  
*Applied harmonized standards or mentioned technical specifications:*

Norme armonizzate / Harmonized standards	
EN 61010-1:2010	Requisiti di sicurezza elettrica / Electrical safety requirements
EN 61326-1:2013	Requisiti EMC / EMC requirements
EN 50581:2012	RoHS / RoHS

Il produttore è responsabile per la dichiarazione rilasciata da:  
*The manufacturer is responsible for the declaration released by:*

Johannes Overhues

Amministratore delegato  
*Chief Executive Officer*

Caselle di Selvazzano, 19/07/2019

Questa dichiarazione certifica l'accordo con la legislazione armonizzata menzionata, non costituisce tuttavia garanzia delle caratteristiche.  
*This declaration certifies the agreement with the harmonization legislation mentioned, contained however no warranty of characteristics.*

# GUARANTEE



Member of GHM GROUP

## TERMS OF GUARANTEE

All DELTA OHM instruments are subject to accurate testing, and are guaranteed for 24 months from the date of purchase. DELTA OHM will repair or replace free of charge the parts that, within the warranty period, shall be deemed non efficient according to its own judgement. Complete replacement is excluded and no damage claims are accepted. The DELTA OHM guarantee only covers instrument repair. The guarantee is void in case of incidental breakage during transport, negligence, misuse, connection to a different voltage than that required for the appliance by the operator. Finally, a product repaired or tampered by unauthorized third parties is excluded from the guarantee. The instrument shall be returned **FREE OF SHIPMENT CHARGES** to your dealer. The jurisdiction of Padua applies in any dispute.



The electrical and electronic equipment marked with this symbol cannot be disposed of in public landfills. According to the Directive 2011/65/EU, the european users of electrical and electronic equipment can return it to the dealer or manufacturer upon purchase of a new one. The illegal disposal of electrical and electronic equipment is punished with an administrative fine.

This guarantee must be sent together with the instrument to our service centre.

**IMPORTANT:** Guarantee is valid only if coupon has been correctly filled in all details.

**Instrument Code:                    HD2060**

Serial Number                    \_\_\_\_\_

## RENEWALS

Date \_\_\_\_\_

Date \_\_\_\_\_

Inspector \_\_\_\_\_

Inspector \_\_\_\_\_

Date \_\_\_\_\_

Date \_\_\_\_\_

Inspector \_\_\_\_\_

Inspector \_\_\_\_\_

Date \_\_\_\_\_

Date \_\_\_\_\_

Inspector \_\_\_\_\_

Inspector \_\_\_\_\_





The quality level of our instruments is the result of the constant development of the product. This may produce some differences between the information written in this manual and the instrument you have purchased. We cannot completely exclude the possibility of errors in the manual, for which we apologize.

The data, images and descriptions included in this manual cannot be legally asserted. We reserve the right to make changes and corrections with no prior notice.

**V1.1**  
**12/05/2020**